

Dishwashing Procedure

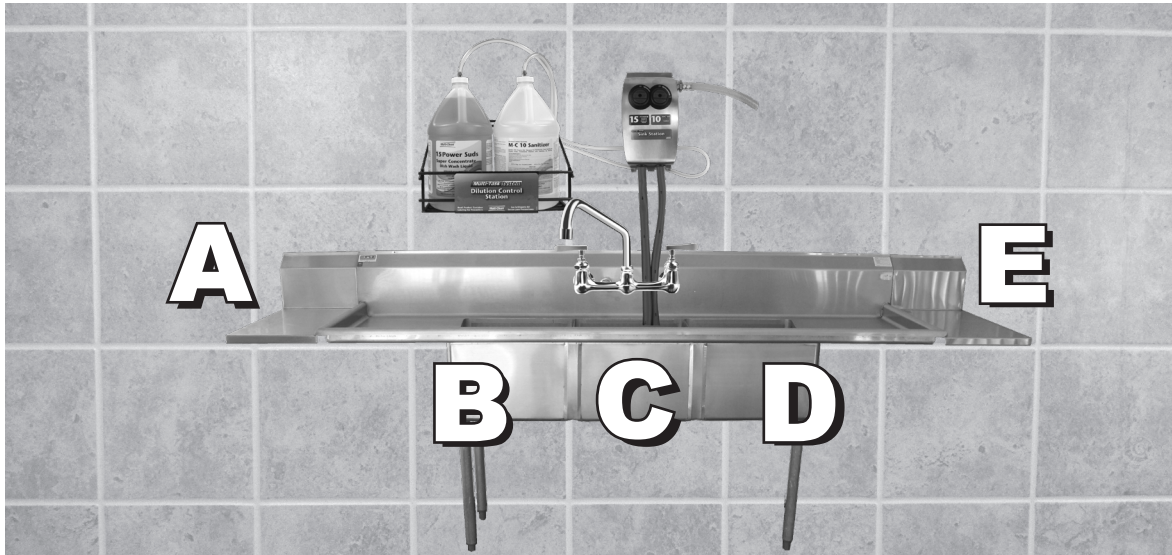

1. Preparation

- Gather all items to be cleaned and place on dishboard “A”.
- Flush, scrape and if necessary, pre-clean items to be washed. Scrape debris into trash receptacle.
- Sinks must be clean before use.

2. Fill Sinks

- Turn on water supply to SINK STATION, then adjust water temperature to warm.
- Fill the first basin “B” to the desired level by turning the **Power Suds** valve on.
- Drain and refill as needed.
- Fill second basin “C” with warm potable water. This is the rinse basin, drain and refill with fresh water as needed.
- Fill the third basin “D” to the desired level by turning the **MC-10 Sanitizer** valve on.
- Periodically test sanitizer solution in basin “D” using quat test strips. Reading should be between 200 and 400ppm.

3. Washing

- Thoroughly wash all items in the first basin.
- Allow soapy water to drain off item and move to the rinse basin “C”. Rinse items in rinse water.
- Move items to the third, sanitize, basin “D”.
- Allow items to soak for at least 1 minute.
- Place items on drying rack “E” to air dry.
- Do not re-rinse or towel dry items.
- Test and change **M-C 10 Sanitizer** solution, periodically to assure solution is effective.



To replace product container when empty:
Remove cap from concentrate and peel back safety cover. Plug into system by simply screwing on cap assembly.



Test and change M-C 10 Sanitizer solution periodically to assure solution is effective. Test strips are available for this test. Item 421200.

Multi-Clean®

600 Cardigan Road
Shoreview, Minnesota

Instructions 004251

Dilution Control Systems

Sink Station Model 421081

In the box:

- Stainless dilution unit
- Bottle Caps and hoses
- Product discharge tubing 5/8 x 60” (2)
- Mounting hardware
- Product identification labels
- Instruction sheet
- Bottle Rack
- Zip ties



This unit is ASSE approved.
ASSE 1066 Type B
Record number 1562



Installation must conform to local plumbing codes and use approved backflow prevention devices. A pressure indicating tee is to be installed with existing faucets according to local plumbing codes in the state of Wisconsin and any other state that requires the use of a pressure indicating tee. Dispensers are equipped with ASSE 1055B Approved backflow devices. Read precautionary information on product SDS prior to handling.

Wear protective clothing, gloves and goggles when installing and handling chemicals. Observe information found on safety data sheets. It is recommended that you calibrate your own dilution ratios during installation. Failure to do so may result in incorrect dilution ratios and lead to products not functioning correctly. Always be sure unit is primed before calibrating. Working pressure range 30-70 PSI (2-5 bar), minimum water flow required, high flow = 2.2 gal/min. Low flow = 0.9 gal/min. Water temperature range 40°F - 150°F (4 - 65°C).

1

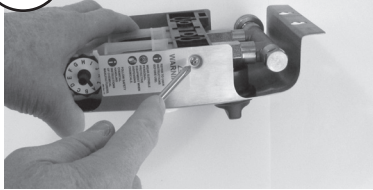

Adjusting Dilution Dials

Loosen 2 cover screws (3mm allen) item 16 and place stainless steel cover aside.

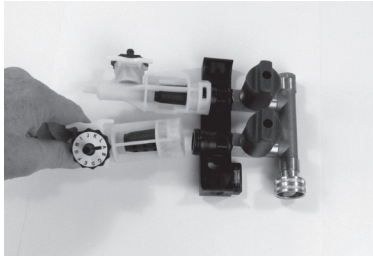

Rotate venturi assemblies counterclockwise 1/4 turn and remove from manifold.

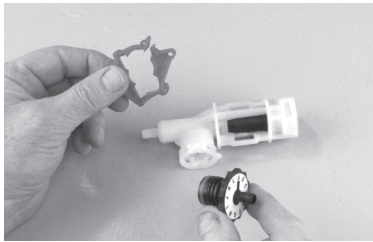

Remove dial clips, item 10, by squeezing and lifting.

Determine required dilution rate using scale on page 3.



Pull dilution dial away from venturi body, rotate dial to: I for 15 for Power Suds. K for MC-10 Sanitizer.

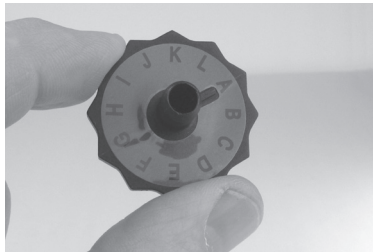

Insert dilution dial into venturi body with the letter selected at the 12 o'clock position.

Replace the dial clip, item 10, making sure it is locked in place.

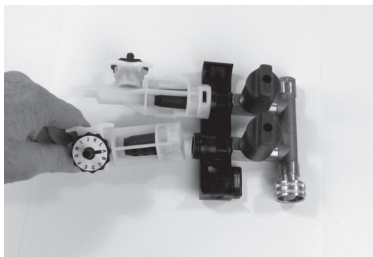

Replace venturi assemblies onto manifold.

Continue to mounting unit to wall.

2

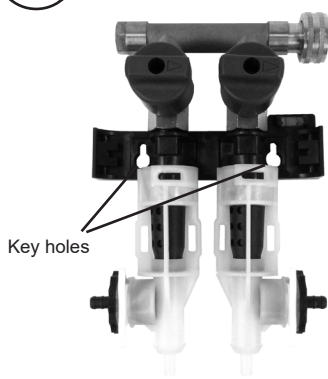

Key holes

Mount Rack to Wall

Using anchors and screws supplied, mount rack to wall making sure product hoses reach to bottle tops. Hoses are 96" long. It is recommended to mount rack on wall to where top of rack is level with the bottom of dispenser cover (item 9). The bottom of rack can be 8 inches or greater from the bottom of the dispenser cover.

3

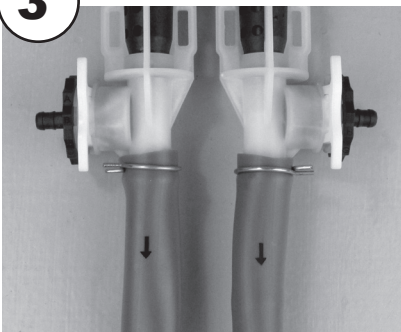

Connecting Discharge Hoses

Slide wire hose clamps over top of hose. Mount hoses to hose barb on bottom of venturi, arrows should be pointing away from unit. Position hose clamps to secure hose to hose barbs. Route hoses to appropriate sink basin. Replace cover and apply product labels supplied to area below valve knob to identify product.

4

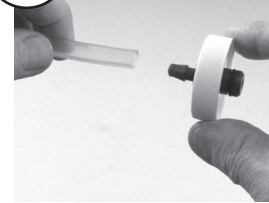

Connecting Chemicals Mount chemical hoses to hose barbs on each venturi assembly. Excess hose length can be cut off if desired. Attach caps to hose ends and attach to each product bottle.

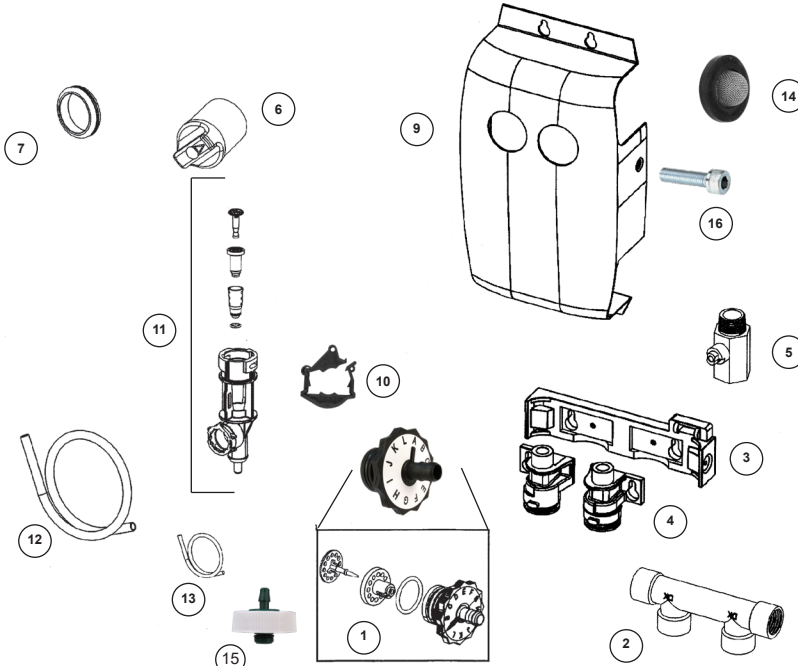

- 1. Dilution dial asm (2)
- 2. Manifold
- 3. Bracket
- 4. Venturi Connector (2)
- 5. Ball valve (2)
- 6. Valve knob (2)
- 7. Valve grommet (2)
- 8. Not used
- 9. Cover
- 10. Dial clip, blue (2)
- 11. Venturi assembly (2)
- 12. Sink fill hose (2)
- 13. Chemical cap hose asm
- 14. Water inlet screen
- 15. Cap
- 16. Cover screw (2)

5

Calibrate Unit

Turn valve to on position. Bleed chemicals to unit. Measure diluted product.

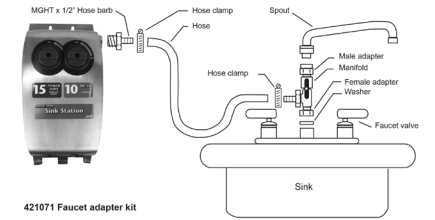

421071 Faucet adapter kit

Optional Faucet adapter kit model 421071
Includes valved manifold and piping adapters for Chicago, Fisher, and T&S faucets.

This unit does not require the use of metering tips, the chart below is for water thin chemicals and is for reference only.

Dial	Dilution Ratio	oz/gal	ml/ltr
None	6:1	18.3	143
A	10:1	11.6	91
B	20:1	6.1	48
C	25:1	4.9	38
D	35:1	3.6	28
E	45:1	2.8	22
F	50:1	2.5	20
G	65:1	1.9	15
H	90:1	1.4	11
I	195:1	0.7	5
J	340:1	0.4	3
K	460:1	0.3	2
L	695:1	0.2	1

Dilution ratios are recorded with water at 40 PSI (2.76 bar) 4 gallons per minute (14 Ltrs/min). Please note that dilution ratios can change as a result of changes to pressure, temperature and chemical viscosity.