

# Dilution Control Systems

# Multi-Task Dispenser Model #421700

OPERATION

SERVICE

PARTS

CARE



Revised 4-06

***Minuteman***<sup>®</sup>  
***Multi-Clean***<sup>®</sup>

# Multi-Task Station Model #421700

Please use this equipment carefully and observe all warnings and cautions.

\*\*\*\*\* NOTE \*\*\*\*\*

<b>WEAR</b>	protective clothing and eyewear when dispensing chemicals or other materials.
<b>ALWAYS</b>	observe safety and handling instructions
<b>ALWAYS</b>	direct discharge away from you or other persons or into approved containers.
<b>ALWAYS</b>	dispense cleaners and chemicals in accordance with instructions. Exercise <b>CAUTION</b> when maintaining your equipment.
<b>KEEP</b>	equipment clean to maintain proper operation.
<b>WEAR</b>	protective clothing and eyewear when working in the vicinity of all chemicals filling or emptying equipment.
<b>ALWAYS</b>	re-assemble equipment according to instruction procedures. Be sure all components are firmly screwed or latched into position.
<b>ATTACH</b>	only to tap water outlets (25 PSI minimum, 85 PSI maximum).
<b>NOTE</b>	if the unit is used to fill a sink or the discharge hose can be placed into a sink, the unit must be mounted so that the bottom of the cabinet is above the overflow rim of the sink.

## Instructions for use

1. For filling hand sprayers and squirt bottles, use the short 9 inch hose.
2. For filling mop buckets, auto scrubbers, carpet extractors, and buddy jugs use the long hose. You may also set up two buttons to fill spray bottles by using the second short hose provided.
3. For filling large containers, depress gray button until it locks into the “on” position. To unlock depress blue eductor lock button on left side of dispensing unit. Only the left button has this feature.
4. When chemical is depleted, unscrew cap and thread onto new bottle.

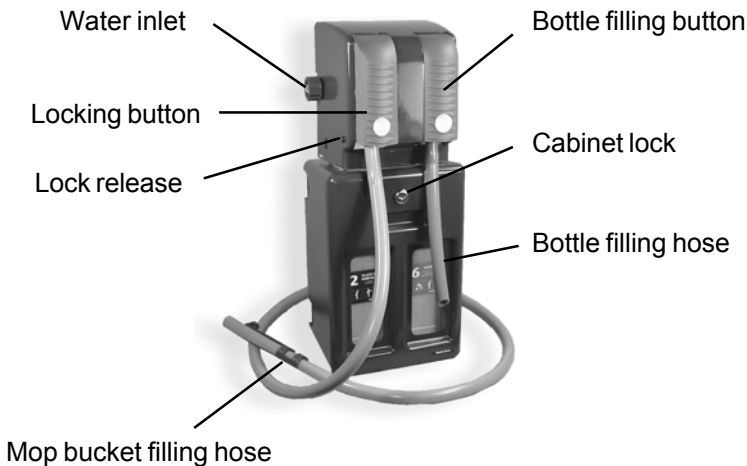

# Mounting Directions

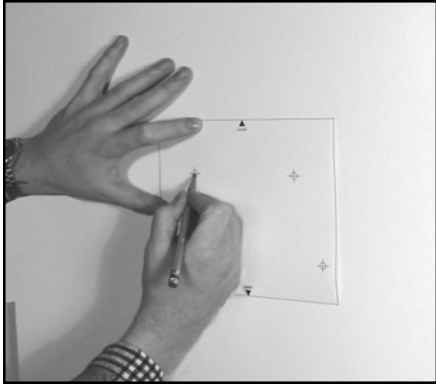

1. Hold template to wall and mark with pencil through template targets where the four holes will be drilled.



2. Drill the marked locations with a 9/32" drill bit and insert anchors (included).

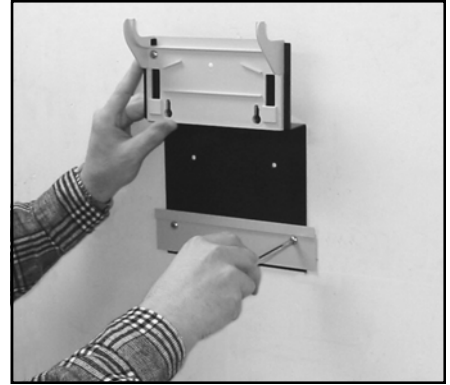

3. Hold bracket to wall and use (4) #10 wood screws (included) to secure bracket and cabinet mount to wall.

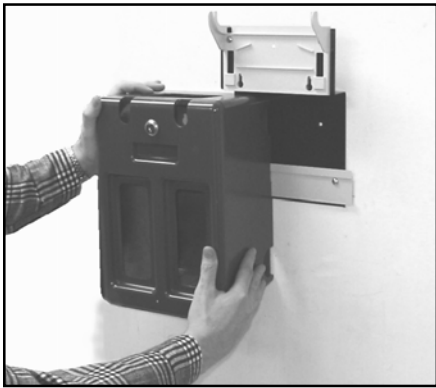

4. Slide cabinet onto the cabinet mount.



5. Mount body of dispenser unit to top of bracket.

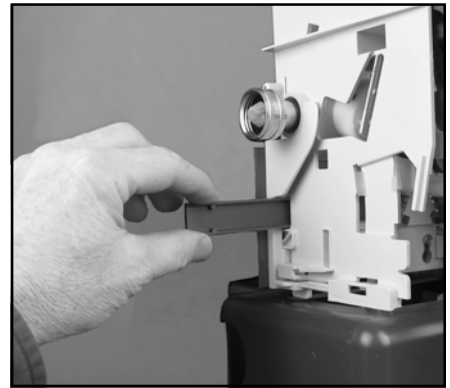

6. Insert bracket lock bar.



7. Mount cover to dispensing unit. Attach discharge hoses to the orange educators. You can cut the 6 foot long hose to 9 inches for dispensing into quart bottles if needed.



8. Attach 8 foot garden hose to water inlet of dispenser unit and water supply.



9. Remove shipping caps on product bottles and thread caps to appropriate bottle. Insert the product bottles into the cabinet and close door. Turn water supply on and dispense product.

To create a 4 button unit, see page 6 for instructions.

# Parts List

Key	Description
1	Strainer Washer
2	Swivel Stem, water inlet
3	Swivel Collar, water inlet
4	Stem, water outlet
5	Valve, Diaphragm, Armature, Spring, Valve
6	Spring
7	Magnet
8	2.5 GPM Flow Washer
9 a	Hose barb brace, left
b	Hose barb brace, right
10	Cap, outlet
11	Magnet Actuator
12	2.5 GPM Eductor Assy Orange
13	Hose Barb 1/4"
14	Cap / Hose Asm 421418
15 a	Hose, Discharge 6 foot
b	Hose, Discharge 9 inches
16	Hose Hook
17	Cover, Dispenser
18	Button, Discharge, Gray
19	Cabinet mount
20	Button unlocking
21	Mounting Bracket
22	Check valve
23	Bracket Lock Bar

## Item Identification



Cabinet



Mounting bracket

Hose hook



Bracket lock bar

Cabinet mount



420118 Hose  
8 feet

# Parts Diagram

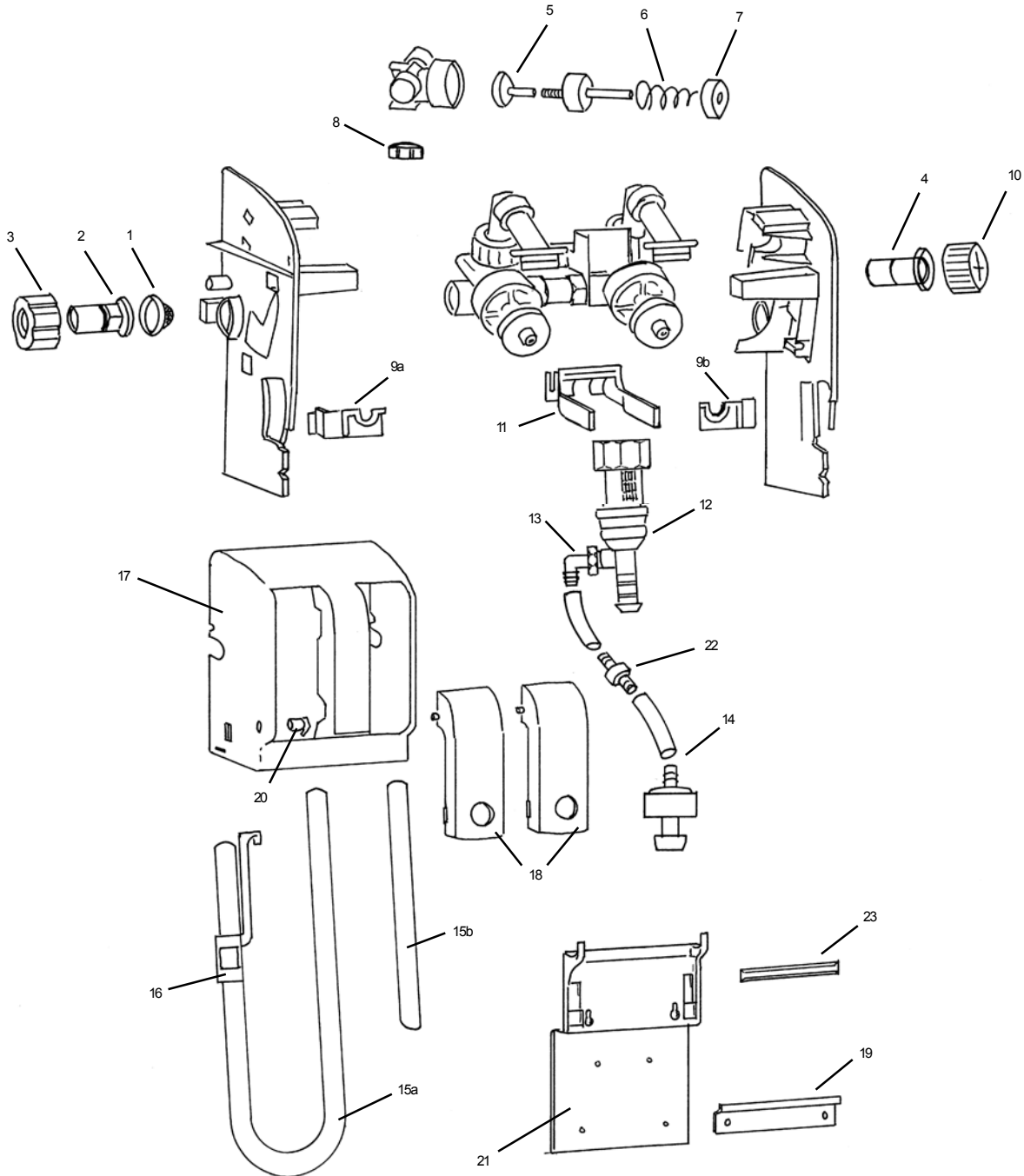

# Troubleshooting Guide

Problem	Cause	Solution
1. No discharge	<ul style="list-style-type: none"> <li>a. No water</li> <li>b. Excessive water pressure</li> <li>c. Clogged water inlet strainer</li> <li>d. Magnetic valve not functioning</li> </ul>	<ul style="list-style-type: none"> <li>a. Open water supply</li> <li>b. Install regulator if flowing water pressure exceeds 85 PSI</li> <li>c. Disconnect inlet water line and clean strainer</li> <li>d. Install valve parts kit</li> </ul>
2. No concentrate draw	<ul style="list-style-type: none"> <li>a. Low water pressure</li> <li>b. Concentrate container empty</li> <li>c. Discharge tube and/or flooding ring not in place</li> <li>d. Clogged water inlet strainer</li> </ul>	<ul style="list-style-type: none"> <li>a. Minimum 25 PSI (with water running) required to operate unit properly</li> <li>b. Replace with full container</li> <li>c. Push tube firmly onto eductor discharge hose barb, or replace tube if it doesn't have a flooding ring</li> <li>d. Disconnect inlet water line and clean strainer</li> </ul>
3. Foaming in discharge	<ul style="list-style-type: none"> <li>a. Concentrate container malfunctioning</li> <li>b. Air leak in pick-up assembly</li> <li>c. Poor vent seal (#9 on parts diagram)</li> </ul>	<ul style="list-style-type: none"> <li>a. Replace with new concentrate container</li> <li>b. Replace pick up assembly with kit</li> <li>c. Replace vent seal</li> </ul>
4. Failure of unit to turn off	<ul style="list-style-type: none"> <li>a. Excessive water pressure</li> <li>b. Magnet doesn't fully return</li> <li>c. Water valve parts dirty or defective</li> </ul>	<ul style="list-style-type: none"> <li>a. Install regulator if pressure (with water flowing) exceeds 85 PSI</li> <li>b. Make sure magnet moves freely Replace spring if short or weak</li> <li>c. Clean or replace with valve parts kit</li> </ul>

# Four Button Station Instructions

The two Multi-Task Dispensers are capable of being connected together to produce a four button station.

1. Tape the wall template to the wall where unit is to be mounted and mark through targets with a pencil.
2. Drill 8 - 9/32" holes and install wall anchors.
3. Mount unit A to wall using screws supplied.
4. Remove hose cap from the right side of unit A .
5. Connect unit B to unit A via hose connectors.
6. Mount unit B to wall using screws supplied.
7. Slide cabinet onto mounting bracket.



## Back Flow Prevention Information

The **Multi-Task Dispenser** from Multi-Clean is equipped with E-Gap Eductors. The purpose of the eductor is to prevent chemicals from contaminating the water distribution system. The terminology used to describe this function is “back flow prevention”.

The back flow prevention built into the Multi-Task Dispenser and other similar dispensing systems is controlled by a National Standard referred as: **ASSE-1055: Performance Requirements for Chemical Dispensers**.

There are two national plumbing codes in force throughout the U.S., the International Plumbing Code (IPC), written by the International Codes Council, and the Uniform Plumbing Code (UPC), written by International Association of Plumbing and Mechanical Officials (IAPMO). States or cities usually adopt one or the other to control plumbing installations in their regions. Both plumbing codes require adherence to ASSE-1055 requirements for chemical dispensing units.

The Multi-Task Dispensers equipped with the E-Gap Eductors meets ASSE-1055 performance requirements and are listed with the ASSE. Look for the UPC ASSE 1055B code compliance sticker on the left side of the unit.



## LIMITED WARRANTY

Multi-Clean Division warrants to the original purchaser/user that this product is free from defects in workmanship and materials under normal use and service for a period of 90 days from date of purchase. In addition, Multi-Clean Division will, at its option, honor labor warranty claims for the first 90 days from date of sale, provided such claims are submitted through and approved by factory authorized repair stations. Multi-Clean Division will, at its option, repair or replace without charge, except for transportation costs, parts that fail under normal use and service when operated and maintained in accordance with the applicable operation and instruction manuals.

This warranty does not apply to normal wear, or to items whose life is dependent on their use and care, such as belts, cords, switches, hoses, rubber parts, electrical motor components or adjustments. Parts not manufactured by Multi-Clean Division such as engines, batteries, battery chargers, hydraulic pumps, and tires are covered by and subject to the warranties and/or guarantees of their manufacturers. Please contact Multi-Clean Division for procedures in warranty claims against these manufacturers.

**Special warning to purchaser** — A potential health hazard exists without exact original equipment replacement.

All warranted items become the sole property of Multi-Clean Division or its original manufacturer, whichever the case may be.

Multi-Clean Division disclaims any implied warranty, including the warranty of merchantability and the warranty of fitness for a particular purpose. Multi-Clean Division assumes no responsibility for any special, incidental or consequential damages.

This limited warranty is applicable only in the U.S.A. and Canada, and is extended only to the original user/purchaser of this product. Customers outside the U.S.A. and Canada should contact their local distributor for export warranty policies. Multi-Clean Division is not responsible for costs or repairs performed by persons other than those specifically authorized by Multi-Clean Division. This warranty does not apply to damage from transportation, alterations by unauthorized persons, misuse or abuse of the equipment, use of non-compatible chemicals, or damage to property, or loss of income due to malfunctions of the product.

If a difficulty develops with this machine, you should contact the dealer from whom it was purchased.

This warranty gives you specific legal rights, and you may have other rights which vary from state to state. Some states do not allow the exclusion or limitation of special, incidental or consequential damages, or limitations on how long an implied warranty lasts, so the above exclusions and limitations may not apply to you.

**Minuteman<sup>®</sup>**  
**Multi-Clean<sup>®</sup>**

*A Member of the Hako Group of Companies*

600 Cardigan Road, Shoreview, Minnesota 55126 USA • Phone (651) 481-1900 Fax (651) 481-9987  
2210 Drew Road, Mississauga, Ontario Canada L5S 1B1 • Phone (905) 673-3222 Fax (905) 673-5161

988444

9-15-05

Printed in U.S.A.