

Dilution Control Systems

CRS Dispenser (Clean-Rinse-Sanitize) Model 421330

■ OPERATION ■ SERVICE ■ PARTS ■ CARE



This dispenser is used with the Travel Station Model #421250
or the Sanitation Station Model #421210

Revised 1/02

Multi-Clean®

Dilution Control CRS Dispenser Model #421330

THANK YOU FOR YOUR INTEREST IN OUR PRODUCTS

Please use this equipment carefully and observe all warnings and cautions.

***** NOTE *****

WEAR	protective clothing and eyewear when dispensing chemicals or other materials.
ALWAYS	observe safety and handling instructions
ALWAYS	direct discharge away from you or other persons or into approved containers.
ALWAYS	dispense cleaners and chemicals in accordance with instructions. Exercise CAUTION when maintaining your equipment.
KEEP	equipment clean to maintain proper operation.
WEAR	protective clothing and eyewear when working in the vicinity of all chemicals filling or emptying equipment or changing metering tips.
ALWAYS	re-assemble equipment according to instruction procedures. Be sure all components are firmly screwed or latched into position.
ATTACH	only to tap water outlets (85 PSI maximum).

The CRS (CLEAN-RINSE-SANITIZE) Dispenser allows dilution and application of concentrated cleaning products, as well as a full volume rinse. The CRS can dispense two products for complete wash/rinse/sanitize functionality.

Package includes:

1. Proportioner in molded plastic cabinet
2. (2) Quick Connect Caps and hose assemblies (48" hose)
3. (1) Metering tip kit
4. (6) Screws, (6) anchors, (6) washers, and a small and large hose clamp for wall mounting CRS Dispenser
5. Strainer washer for water inlet
6. Parts list and product structure diagram (in this booklet)

The CRS Dispenser is designed for use with either one of the following Dilution Control Systems listed below:

1. **Travel Station:** This is a two-wheel cart mounted mobile station. It is packed and shipped in 4 separate cartons. Complete instructions and mounting hardware are enclosed with the wire frame rack. The CRS Dispenser is first attached to a wire frame mounting rack which then allows attachment to the two-wheel cart.
2. **Sanitation Station:** This system is stationary. It comes with separate wire frame rack to hold chemical concentrates. This station is packed in 2 separate cartons. The CRS Dispenser is mounted directly to a wall and comes complete with wall mounting hardware.

Instructions for Operation: (See parts diagram if unfamiliar with part names.)

1. Turn valve hands into the 'Off' position (handles up). Remove cover by squeezing the latch at the bottom center of cabinet and slowly lifting upward.
2. Select metering tip (see next two sections) and press firmly into hose barb provided at the side of the eductor. You will need to select two tips, one for the cleaner/detergent product, and one for the disinfectant/sanitizer. Slip the open end of the Quick Connect Cap/Hose Assembly over the hose barb/metering tip. Screw the cap onto the appropriate concentrate container.
3. A label showing which valve provides rinse is pre-installed on the middle handle of the CRS Dispenser.
4. Connect inlet and discharge hoses. Connect the inlet supply (8 feet) to the upper left fitting and the discharge (25 feet) to the lower right fitting. **Be sure the dispenser is connected to water supply that is protected with a back flow preventer which meets local codes.** Water supply must provide a minimum of 25 PSI flowing water pressure at 3 GPM to operate this dispenser.
5. For wall mounting use the hose clamp that fits tightly on discharge hose to secure the hose to the wall. This will avoid putting undue stress on the discharge fitting, manifold, and mounting hardware in the event the hose gets pulled.
6. Screw the pistol grip nozzle onto the end of the 25 foot discharge hose. Place a brass (female) Quick Connect Coupling onto the threaded end of the pistol grip nozzle.
7. Attach the sprayer/foam wand assembly to the Quick Connect Couplings. When using the CRS Dispenser, product may be dispensed using the foam wand. The wand can also be removed by pulling the end off, if a spray (for rinsing or applying sanitizer) is desired.

8. Apply color coded labels directly below the lever that corresponds with the product being dispensed.
9. Turn on the water supply.
10. Turn the product valve 90 degrees counter clock wise to turn the unit on. To prime, operate the unit until the solution is just being dispensed. Shut off the valve and turn on rinse lever to rinse out hose. Prime second product tube in the same manner. When finished priming be sure all handles are straight up in the off position.
11. Replace the cover by slipping upper tab into and lowering the lid. Make sure all sides are aligned. You may need to push up slightly on the bottom of the cabinet back, near the latch, to secure the cover.

Measurement of Concentration:

You can determine the dispensed water-to-product ratio for any metering tip size and product viscosity by operating the primed dispenser for about a minute and note two things:

1. The amount of dispensed water/product mixture.
2. The amount of concentrate used in preparation of the solution dispensed.

Tip Selection Chart

Product	Heavy Cleaning Color-Dilution	Normal Cleaning
#3 Soap Scum	Black 1:20	Red 1:32
#4 F.A.S.T.	Black 1:20	Red 1:32
#10 MC-10 Sanitizer	Green 1:160	Pink 1:512
#12 Foaming F.S.D.	Black 1:20	Red 1:32
#64 Ful-Trole 64	Blue 1:64 (Hospital Grade)	Tan 1:100 (Institutional Grade)
#256 Century Q	Blue 1:64	Purple 1:256

TROUBLESHOOTING CHART:

Problem	Cause	Solution
1. No discharge	a. No water b. Eductor clogged	a. Open water supply, see that the inlet strainer isn't clogged b. Clean* or replace
2. No concentrate draw	a. Clogged check valve b. Metering tip clogged c. Eductor clogged d. Clogged water inlet e. Low water pressure and/or volume f. Concentrate container empty g. Check valve not screwed into eductor tightly	a. Clean* or replace b. Rinse in hot water or replace: DON'T REAM! c. Clean* or replace d. Clean screen e. Minimum 25 PSI flowing and 3 GPM flow required to operate unit f. Replace with full container g. Tighten, but do not overtighten
3. Excess concentrate draw	a. No metering tip or wrong one	a. Press correct tip firmly into barb
4. Water won't shut off	a. Valve defective	a. Replace
5. Excess foaming in discharge	a. Inlet screen clogged b. Supply source inadequate c. Scaled eductor or fittings	a. Clean* or replace b. 3 GPM flow necessary through unit. Move unit or replumb incoming line c. Clean* or replace
6. Supply water into concentrate or unit won't hold prime	a. Check valve inoperable	a. Clean* or replace check valve

* In hard water areas, scale may form inside the discharge end of the eductor. This scale may be removed by soaking the eductor in a descaling (deliming) solution or running a descalant through the system. When removing an eductor for soaking firmly grasp the eductor and unthread the adapters located above and below the eductor. Replace in same manner. Alternatively, a scaled eductor can be cleaned (or kept from scaling) by drawing the descaling solution through the unit. Operate the unit with the suction tube in the descaling solution. Operate the unit until solution is drawn consistently, then flush the unit by drawing clear water through it for a minute. Replace concentrate container and put suction tube into concentrate.

CRS Dispenser Diagram

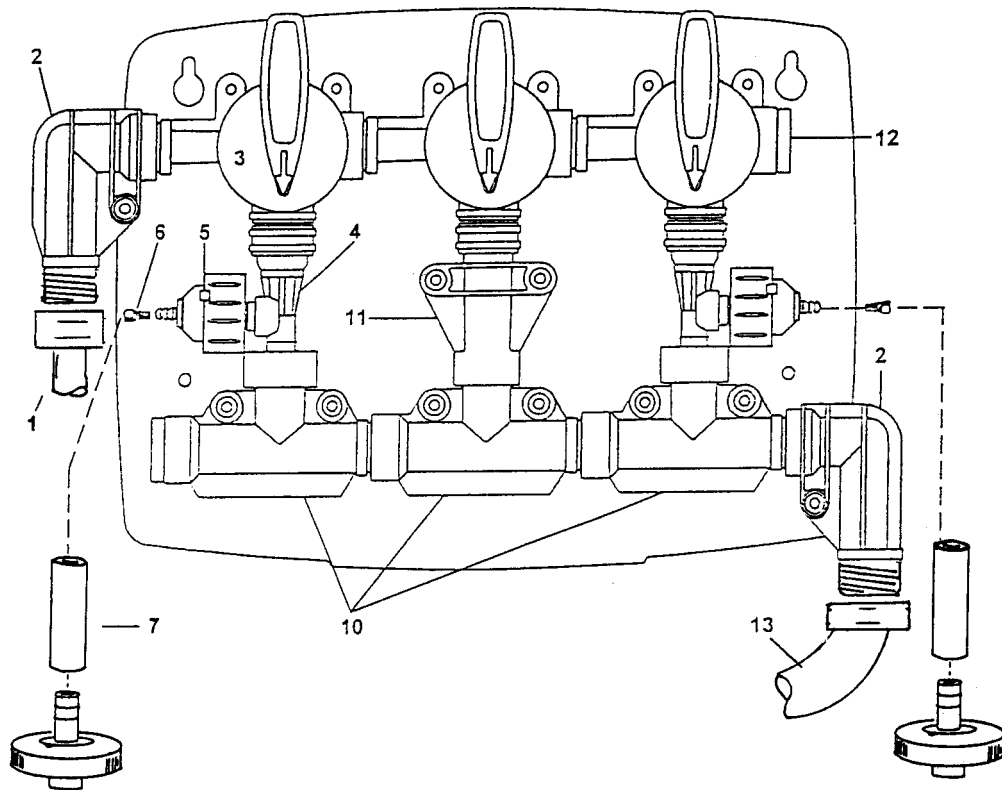

Parts List

Key	Part #	Description
1	420118	Inlet Hose
2		Elbow
3		Valve Assembly, Including Handle
4		3.5 GPM Venturi (Light Brown)
5	421312	Check Valve: Blue – 3 PSI Yellow – 1 PSI
6		Metering Tip Kit
7	421336	Quick Connect Cap/Hose Assembly
10		Tee
11		Connecting Tube
12		Plug
13	420125	Outlet Hose

Not Shown:
 Hose Washer
 Cabinet Set
 1/2" Hose Clamp
 3/4" Hose Clamp

Spray Nozzle/Foam Wand

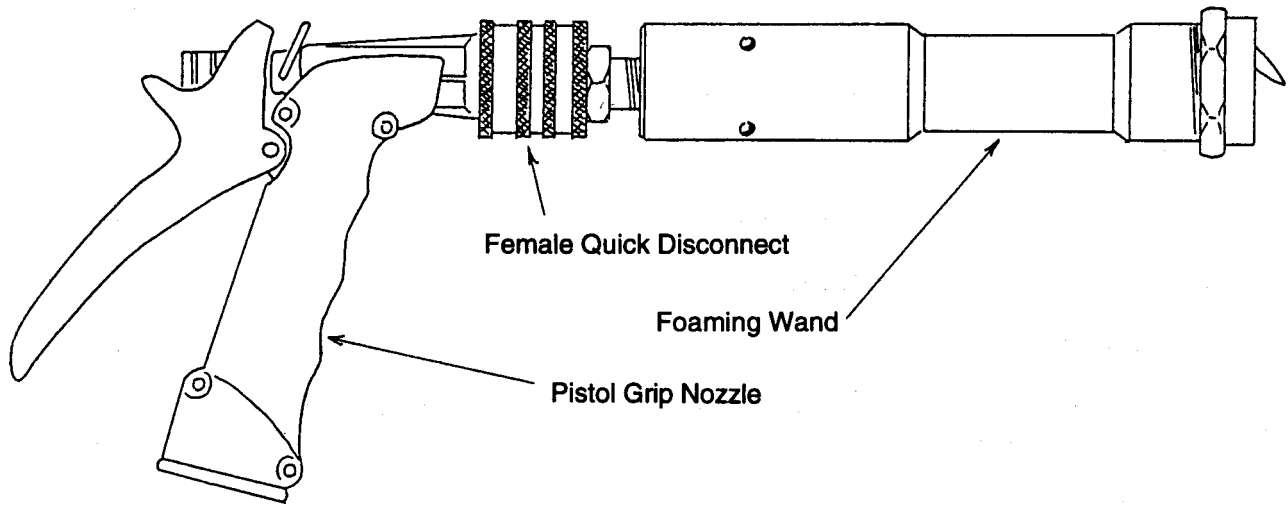

These items are packaged separately:

Parts List

Key	Part #	Description
1	421025	Foaming Wand
2	421311	Female Quick Disconnect
3	421030	Pistol Grip Nozzle
	420118	Supply Hose (8 Ft.)
	420125	Discharge Hose (25 Ft.)

CRS Dispenser: Wall Mount Instructions

The Sanitation Station requires the CRS Dispenser to be mounted directly to a wall. Select a convenient height and mount the dispenser within 36 inches of the wall mount concentrate rack.

1. The CRS Dispenser comes with a wall mount kit for solid walls or mounting to studs. A butterfly anchor may be required for hollow walls.
 2. Remove cover from dispenser. Hold up to wall and mark hole locations with a pencil.
 3. Drill holes into wall using a 5/16" bit. Tap in anchors. Drive 2 screws into the upper holes until there is a 1/8" space left between the wall and the screw head.
 4. Set the CRS Dispenser onto the screws through the keyhole openings on the back of the dispenser. Tighten if necessary.
 5. Locate lower holes and screw into wall. Do not over tighten.
 6. Replace rack cover.
-

CRS Dispenser: Cart Mount Instructions

The Travel Station requires the CRS Dispenser to be mounted on a wire frame rack which is then mounted on the cart.

1. Locate each of the 4 cartons for the Travel Station. Open the carton labeled 'CRS Mount Rack'. Locate instructions detailing how to mount the CRS Dispenser to the rack and the associated hardware for mounting.
2. Attach the CRS Dispenser to the rack.
3. Open the carton labeled 'Two-Wheel Cart' and assemble as directed. Locate hardware for mounting concentrate rack.
4. Attach the entire rack to the cart as directed.
5. Open the carton labeled 'Concentrate Rack'. Attach the rack to the cart using the instructions and hardware that are in the cart.
6. Follow instructions for operation.

LIMITED WARRANTY

Multi-Clean Division warrants to the original purchaser/user that this product is free from defects in workmanship and materials under normal use and service for a period of 90 days from date of purchase. In addition, Multi-Clean Division will, at its option, honor labor warranty claims for the first 90 days from date of sale, provided such claims are submitted through and approved by factory authorized repair stations. Multi-Clean Division will, at its option, repair or replace without charge, except for transportation costs, parts that fail under normal use and service when operated and maintained in accordance with the applicable operation and instruction manuals.

This warranty does not apply to normal wear, or to items whose life is dependent on their use and care, such as belts, cords, switches, hoses, rubber parts, electrical motor components or adjustments. Parts not manufactured by Multi-Clean Division such as engines, batteries, battery chargers, hydraulic pumps, and tires are covered by and subject to the warranties and/or guarantees of their manufacturers. Please contact Multi-Clean Division for procedures in warranty claims against these manufacturers.

Special warning to purchaser — A potential health hazard exists without exact original equipment replacement.

All warranted items become the sole property of Multi-Clean Division or its original manufacturer, whichever the case may be.

Multi-Clean Division disclaims any implied warranty, including the warranty of merchantability and the warranty of fitness for a particular purpose. Multi-Clean Division assumes no responsibility for any special, incidental or consequential damages.

This limited warranty is applicable only in the U.S.A. and Canada, and is extended only to the original user/purchaser of this product. Customers outside the U.S.A. and Canada should contact their local distributor for export warranty policies. Multi-Clean Division is not responsible for costs or repairs performed by persons other than those specifically authorized by Multi-Clean Division. This warranty does not apply to damage from transportation, alterations by unauthorized persons, misuse or abuse of the equipment, use of non-compatible chemicals, or damage to property, or loss of income due to malfunctions of the product.

If a difficulty develops with this machine, you should contact the dealer from whom it was purchased.

This warranty gives you specific legal rights, and you may have other rights which vary from state to state. Some states do not allow the exclusion or limitation of special, incidental or consequential damages, or limitations on how long an implied warranty lasts, so the above exclusions and limitations may not apply to you.

Multi-Clean®

600 Cardigan Road, Shoreview, Minnesota 55126 USA • Phone (651) 481-1900 Fax (651) 481-9987
2210 Drew Road, Mississauga, Ontario Canada L5S 1B1 • Phone (905) 673-3222 Fax (905) 673-5161

988363
Printed in U.S.A.