

# Dilution Control Systems

# Sanitation Dispenser Model 421331

OPERATION

SERVICE

PARTS

CARE



## Sanitation Station Dispenser

Wall mounted, high volume washing, foaming, and or sanitizing proportioner with two product eductors.

Multi-Clean manufactures quality proportioning equipment. Please use this equipment carefully and observe all warnings and cautions.

### Note:

Do not exceed water temperature of 140°F.

Wear protective clothing and eyewear when dispensing chemicals.

Always observe safety and handling instructions on product bottle or MSDS.

Always direct discharge away from you or other persons or into approved container.

Clean equipment after each use.

Attach only to tap water outlets not exceeding 140°F and 85 PSI maximum.

### Package includes:

- Complete unit mounted on stainless steel front plate
- (2) 7-foot vinyl product suction tubes with foot strainers,(2) Cap hose asm
- (1) metering tip kit
- (4) screws and (4) wall anchors for wall mounting (use 9/32" drill)
- Hose hanger

### Instructions for Operation:

1. Attach unit to wall using hardware provided.
2. Select metering tip (see section on metering tip selection) and press firmly into hose barb provided at the side of the eductor. Install product suction tube on hose barb.
3. Connect water inlet hose with 3/4" male garden thread to female swivel at top left side of unit. Tighten to avoid leaking.
4. Connect discharge hose to male 3/4" discharge provided at bottom of unit. Hose of 1/2" ID is recommended if the hose length will be 50 feet or less. Use 3/4" ID hose if the total length of the hose will exceed 50 feet.
5. Turn on water supply to unit. Minimum 25 PSI water pressure is required to operate the unit.
6. Turn on product valve to begin proportioning and dispensing. Shut off the valve and turn on rinse (bottom) lever for full volume rinse. Note: You may only use either one product or the rinse feature - only one valve may be in use at a time.

### Tip Selection Chart

Product	Heavy Cleaning Tip Color-Dilution	Normal Cleaning Tip Color-Dilution
#10 MC-10 Sanitizer	Pink 1:512	Pink 1:512
#12 HD-Hi-Foam	Red 1:32	Green 1:64

APPROXIMATE DILUTIONS AT 40 PSI FOR WATER-THIN PRODUCTS (1.0 CP)			
Tip Color	Orifice Size	Std. Drill Number)	Ratio
No Tip	.187	(3/16)	10:1
Gray	.128	(30)	10:1
Black	.098	(40)	10:1
Beige	.070	(50)	12:1
Red	.052	(55)	16:1
White	.043	(57)	24:1
Blue	.040	(60)	28:1
Tan	.035	(65)	32:1
Green	.028	(70)	48:1
Orange	.025	(72)	64:1
Brown	.023	(74)	80:1
Yellow	.020	(76)	96:1
Aqua	.018	(77)	128:1
Purple	.014	(79)	256:1
Pink	.010	(87)	384:1
Lt. Purple	.009	(89)	512:1

CONVERSION CHART: Ratio Equivalents to Standard Measures		
Oz./Gal.	Ratio	%
128	1:1	50.0
64	2:1	33.3
32	4:1	20.0
21	6:1	14.3
16	8:1	11.1
14	9:1	10.0
8	16:1	5.9
6	24:1	4.0
4	32:1	3.0
3	48:1	2.0
2	64:1	1.5
1	128:1	0.8
1/2	256:1	0.4
1/4	512:1	0.2

**Measurement of Concentration:**

You can determine the dispensed water-to-product ratio for any metering tip size and product viscosity. All that is required is to operate the primed dispenser for a minute or so and note two things: the amount of dispensed water/product mixture, and the amount of concentrate used in preparation of the solution dispensed. The water-to-product ratio is then calculated as follows:

$$\text{Dilution (X)} = \frac{\text{Amount of Mixed Solution -- Amount of Concentrate Drawn}}{\text{Amount of Concentrate Drawn}}$$

Dilution ratio, then, equals X parts water to one part concentrate (X:1). If the test does not yield the desired ratio, choose a different tip and repeat the test. Alternative methods to this test are 1) pH (using litmus paper), and 2) titration. Contact your concentrate supplier for further information on these alternative methods and the materials required to perform them.

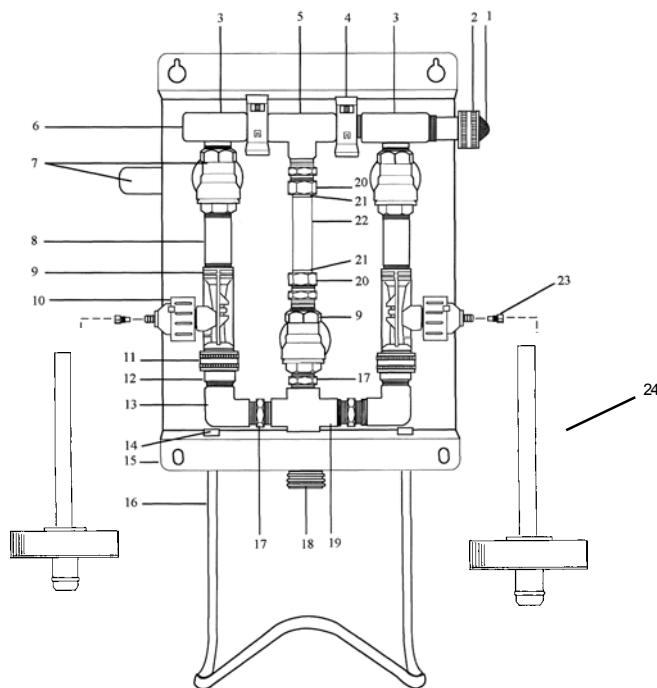

- 1 Strainer washer
- 2a Connector swivel, stem
- b Swivel nut
- 3 Branch Tee
- 4 Clamp
- 5 Tee
- 6 Pipe plug
- 7a Ball valve
- b Nut
- 8 Pipe nipple
- 9 3.5 GPM eductor
- 10 Check valve
- 11 Swivel nut
- 12 Swivel stem, short
- 13 Discharge elbow
- 14 Nut
- 15 Cover
- 16 Hose hanger
- 17 Hex nipple
- 18 Hose connector adapter
- 19 Cross
- 20a Compression fitting
- b Nut
- 21 Brass sleeve
- 22 Tube
- 23 Metering tip
- 24 Draw tube

## LIMITED WARRANTY

Multi-Clean Division warrants to the original purchaser/user that this product is free from defects in workmanship and materials under normal use and service for a period of 90 days from date of purchase. In addition, Multi-Clean Division will, at its option, honor labor warranty claims for the first 90 days from date of sale, provided such claims are submitted through and approved by factory authorized repair stations. Multi-Clean Division will, at its option, repair or replace without charge, except for transportation costs, parts that fail under normal use and service when operated and maintained in accordance with the applicable operation and instruction manuals.

This warranty does not apply to normal wear, or to items whose life is dependent on their use and care, such as belts, cords, switches, hoses, rubber parts, electrical motor components or adjustments. Parts not manufactured by Multi-Clean Division such as engines, batteries, battery chargers, hydraulic pumps, and tires are covered by and subject to the warranties and/or guarantees of their manufacturers. Please contact Multi-Clean Division for procedures in warranty claims against these manufacturers.

**Special warning to purchaser** — A potential health hazard exists without exact original equipment replacement.

All warranted items become the sole property of Multi-Clean Division or its original manufacturer, whichever the case may be.

Multi-Clean Division disclaims any implied warranty, including the warranty of merchantability and the warranty of fitness for a particular purpose. Multi-Clean Division assumes no responsibility for any special, incidental or consequential damages.

This limited warranty is applicable only in the U.S.A. and Canada, and is extended only to the original user/purchaser of this product. Customers outside the U.S.A. and Canada should contact their local distributor for export warranty policies. Multi-Clean Division is not responsible for costs or repairs performed by persons other than those specifically authorized by Multi-Clean Division. This warranty does not apply to damage from transportation, alterations by unauthorized persons, misuse or abuse of the equipment, use of non-compatible chemicals, or damage to property, or loss of income due to malfunctions of the product.

If a difficulty develops with this machine, you should contact the dealer from whom it was purchased.

This warranty gives you specific legal rights, and you may have other rights which vary from state to state. Some states do not allow the exclusion or limitation of special, incidental or consequential damages, or limitations on how long an implied warranty lasts, so the above exclusions and limitations may not apply to you.



600 Cardigan Road  
Shoreview, Minnesota 55126 USA  
Phone 651- 481-1900  
Fax 651- 481-9987  
[www.multi-clean.com](http://www.multi-clean.com)

988363  
12/2010